



Servo Drives AC / DC

■ Introduction

HCB Servo Drive



The compact single-axis servo drives of the HCB series are true all-rounders in drive technology. They combine maximum power density with extensive motion control functions.

HCL Low Voltage Servo Drive



In addition to the integrated controllers, the HCL servo controller series can be perfectly combined with our 24 V and 48 V motors of the HMD Next Generation series.

With a maximum current of up to 225 A peak, the controllers, in combination with our HMD servomotors, offer an ideal solution for demanding tasks.

■ Content

Order Code	Page
HCBServo Drive	4
HCL Low Voltage Servo Drive	5
HCBServo Drive	
Introduction	6
Hardware Equipment	8
Software Functions	9
Approvals	10
Connections	11
Specifications Single-phase	12
Specifications Three-phase	14
Connectors Single-phase	16
Connectors Three-phase	18
HCL Low Voltage Servo Drive	
Introduction	20
Hardware Equipment	22
Specifications HCL 60 C	24
Specifications HCL 120 C / HCL 120 E	26
Specifications HCL 225 CS	28
Specifications HCL 225 C / 225 E	30
Connectors HCL 60 C / HCL 120 C / HCL 120 E	32
Connectors HCL 225 CS / HCL 225 C / HCL 225 E	34

Order Code

HCB Servo Drive

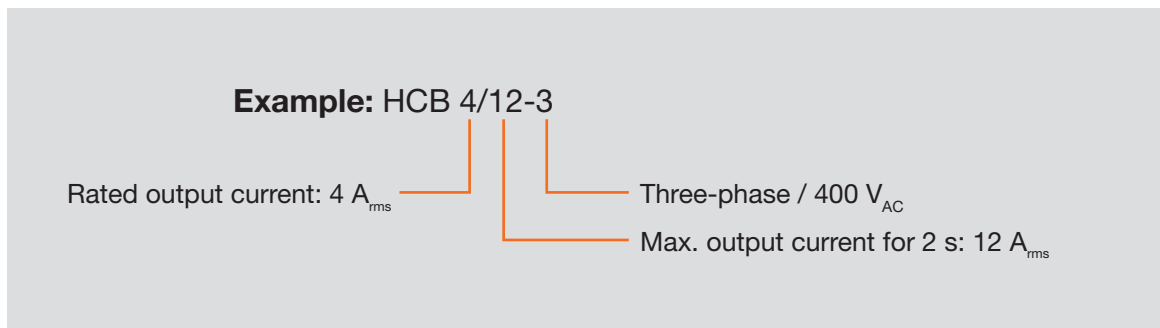
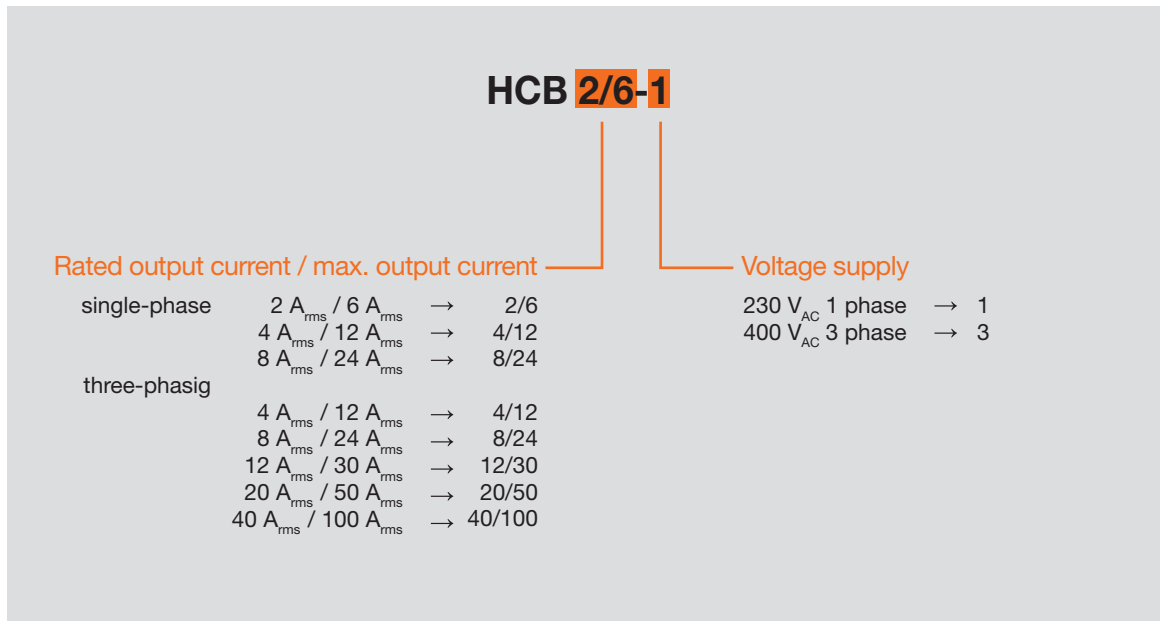

■ HCL Low Voltage Servo Drive

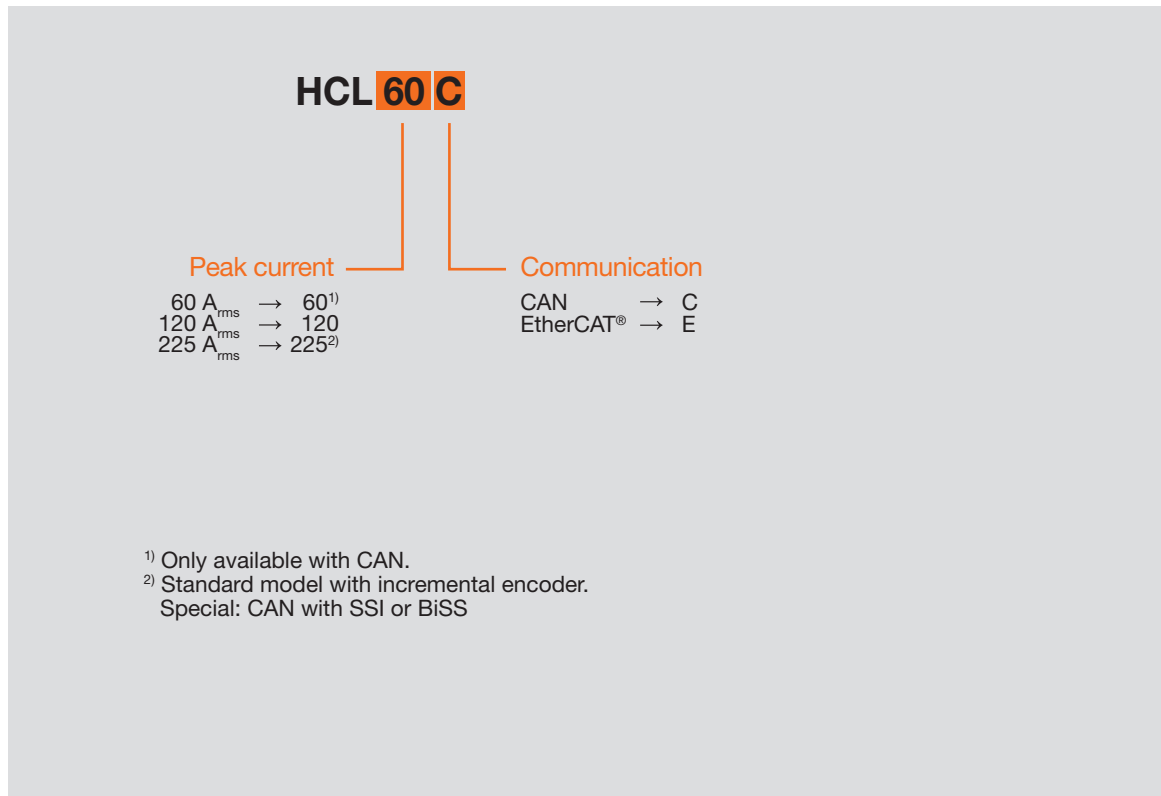

■ HCB Servo Drive

Introduction

■ General Information

The compact single-axis servo drives of the HCB-series are true all-rounders in drive technology. They combine maximum power density with extensive motion control functions. The HCB-series consists of two sizes, which are divided into two power stages for the 1-phase units and three power stages for the 3-phase units. All proven fieldbus interfaces are “on board” – from CANopen® to EtherCAT® to PROFINET®, which promise problem-free communication. Its versatility is further underlined by the numerous encoder interfaces, also for single-cable solutions. Complex positioning tasks through linked position sets can be interconnected. The position-synchronous or speed- synchronous motion of various drives with variable gear ratios can be quickly parameterised via the software assistant. Rotary table applications, position triggers, rotor position triggers or switching cams – a wide range of dynamic application tasks can be handled via the integrated software functions.

In combination with the HeiMotion servo motors with encoder variant matched to your application and a gearbox from the HMPG series mounted in the gearbox direct attachment, you get a customized drive axis from a single source at an unbeatable price-performance ratio.



General Properties

Functions *

- Safety function "Safe Torque Off" (STO)
- Realization of functionality SS1 possible
- Switching cams
- Direct control of the holding brake in the motor
- Automatic determination of motor parameters
- Position set-dependent synchronization possible
- Path program / linking
- Integrated position control
- Parameterizable belt locks

* Some functions are not available for all models.

Ambient Conditions

Ambient temperature in operation:	0 °C to +40 °C +40 °C to +50 °C with power reduction 2.5 % / K
Storage temperature:	-25 °C to +70 °C
Operating and storage humidity:	Relative humidity 90 % (without condensation)
Protection class:	IP20
Installation altitude:	Mounting height max. 2000 m above sea level, above 1000 m above sea level with power reduction 1 % per 100 m
Degree of pollution:	2
Type of installation	Installation in switch cabinet with at least protection class IP54

Climate Conditions

During operation	According to EN 61800-2, IEC 60721-3-3 class 3K3 ¹⁾
	Temperature: 0 °C to + 40 °C (4 kHz), to 50 °C with power reduction (2,5 % /K)
	Relative humidity: 90 % without condensation

¹⁾ Absolute humidity is limited to maximum 25 g/m³.
That means that the maximal values for temperature and relative humidity listed in the table must not occur simultaneously.

■ HCB Servo Drive

Hardware Equipment

■ Hardware Equipment

In-/outputs

2 analog inputs (± 10 V DC, 12 bit)

8 digital inputs / 3 outputs - standard

Motor temperature sensor: PTC, NTC, KTY84-130, o.s.

Encoder Systems (Singleturn and Multiturn)

EnDAT® 2.2

HIPERFACE®

HIPERFACE DSL®

Resolver

Analog and digital incremental encoders with / without commutation signal

SSI resp. BiSS C

Safety Technology

STO - Safe Torque Off

■

Integrated safety control

-

EMV Approvals

Integrated mains filter C2 (10 m) / C3 (25 m)

-

External mains filter C2 (10 m) / C3 (30 m)

□

External mains filter C2 (100 m) / C3 (150 m)

-

Approvals

CE, UL

Field Bus Systems

CANopen®

EtherCAT®

PROFINET®

Technology

Second SinCos-Geber	SinCos encoder with ZP, SSI, EnDat® 2.2	□
	SSI encoder	□
	digital EnDat® 2.2 encoder	□
	TTL encoder	□
One cable system with HIPERFACE DSL® encoder		□
TTL encoder simulation		□
SSI encoder simulation		-
TTL master		□
TTL encoder with commutation signals		□
Bidirectional axis cross communication (TwinSync, max. 2 axes)		-

Cooling Concept

Air cooling

■

■ Software Functions (Heidrive ServoCommander)

Commissioning

Automatic motor identification
Automatic encoder offset determination
Autotuning

Connectable Motors

Permanent-magnet synchronous machines with sinusoidal EMF
Torque motors
Air-core and iron-core linear motors with a low motor inductance (0.5...4 mH)

Control Types

Torque / power control
Speed control
Position control

Motor Systems

Rotative asynchronous motors	■
Rotative synchronous motors	■
Linear synchronous motors	■

Motion Profile

Point-to-point positioning
Synchronous movement / electronic gear
Round axis
Cam disks
Virtual master: CANopen, CiA DSP402
Standard-compliant movement profiles

Technology

Programmable in IEC 61131	<input type="checkbox"/>
---------------------------	--------------------------

■ HCB Servo Drive

Approvals

■ Approvals

CE

Meets low-voltage directive 2014/35/EU and the product regulation EN 61800-5-1

UL/CSA

HCB 1-phase & HCB 3-phase: UL 61800-5-1, CSA C22.2, No. 274

EMV

- Interference immunity according to EN 61800-3 environment class 1 and 2
- HCB 1-phase: Public low-voltage network: "First and second environment" (residential area C2 / industrial area C3) up to 25 m motor cable length
- HCB 1-phase & HCB 3-phase: Industrial low-voltage network: "Second environment" (industrial area C3) up to 25 m motor cable length

STO (Integrated Safety Functions)

- EN 61800-5-2
- EN ISO 13849-1 "PL e"
- EN 61800-5-2 / IEC 61508 / EN 62061 "SIL 3" / "SIL CL 3"

The approval was conducted by the accredited certification agency "TÜV Rheinland"

■ Connections / Inputs and Outputs

Connection	Function
X1	I/O communication
X2A	Resolver connection
X2B	Multi-encoder connection
X3	STO interface (STOA, STOB), limit switch (DIN6, DIN7) Dig. output (DOUT0)
X4	CANopen®
X6	Motor connection
X6A	Motor brake / HIPERFACE DSL® (HCB 3-phase)
X9	Voltage supply
X9A	Brake resistor (HCB 3-phase)
X9B	24V supply (HCB 3-phase)
X18	Ethernet interface
X19	USB interfae
X21	Realtime Ethernet interface

Power Cable

Length	Heidrive-No.
3 m	14-007-051-18-0
5 m	14-007-051-19-0
10 m	14-007-051-23-0

Signal Cable (Resolver)

Length	Heidrive-No.
3 m	14-007-051-60-0
5 m	14-007-051-62-0
10 m	14-007-051-67-0

Signal Cable (HIPERFACE®)

Length	Heidrive-No.
3 m	14-007-051-78-0
5 m	14-007-051-80-0
10 m	14-007-051-85-0

■ HCB Servo Drive

Single-phase

■ Specifications

	HCB 2/6-1	HCB 4/12-1	HCB 8/24-1
Voltage supply	230 V _{AC} [± 10 %], 50...60 Hz		
Control voltage	24 V _{DC} [± 20 %] (0.35 A)		
DC link voltage	325 V _{DC} (with U _{mains} = 230 V _{AC})		
Output power	400 W	800 W	1.6 kW
Max. output power for 2 s	1 kW	2 kW	4.8 kW
Rated output current	2 A _{rms}	4 A _{rms}	8 A _{rms}
Max. output current for 2s	6 A _{rms}	12 A _{rms}	24 A _{rms}
Internal brake resistor	75 Ω		30 Ω
Continuous power / pulse power	bis 2 kW		6.4 kW
External brake resistor	75 Ω, max. 2 kW		≥ 30 Ω
Holding brake	24 V _{DC} , max. 2 A		
Dimensions servo drive H x W x D	200 x 50 x 163 mm 245 x 50 x 163 mm with mounting plate		230 x 67 x 200 mm 275 x 67 x 200 mm with mounting plate
Weight	1.5 kg		2.9 kg
Encoder evaluation	EnDat® 2.2, HIPERFACE®, HIPERFACE DSL®, resolver, analog and digital incremental encoders with/without commutation signals, BiSS (Type C)		
Interfaces	USB 2.0, Ethernet, CAN bus, EtherCAT®, PROFINET®, MicroSD card		
Inputs / outputs	8 x digital in (24 V _{DC}), 2 x analog in (± 10 V) 3 x digital out (24 V _{DC})		
Product numbers	12-225-020-01-0	12-225-020-02-0	12-225-020-03-0

Dimensional Drawing HCB 2/6-1 and HCB 4/12-1

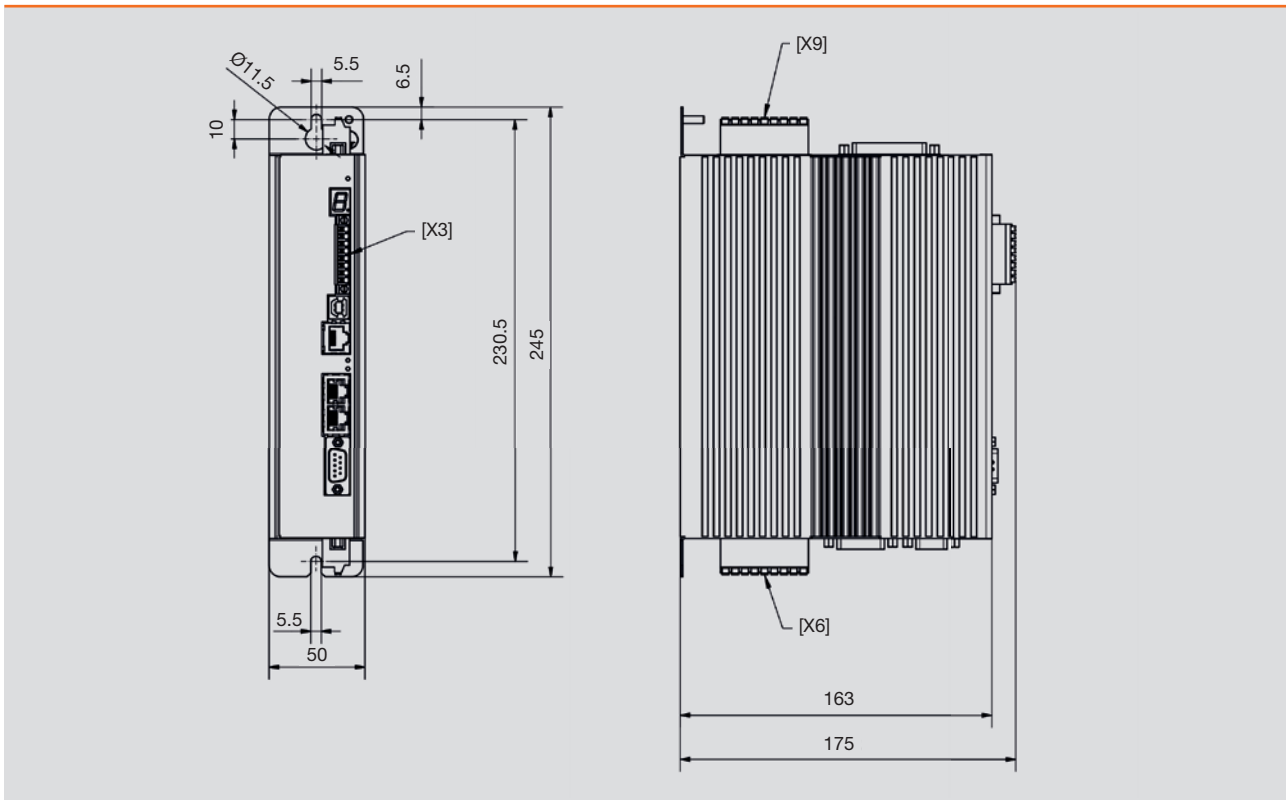

Dimensional Drawing HCB 8/24-1

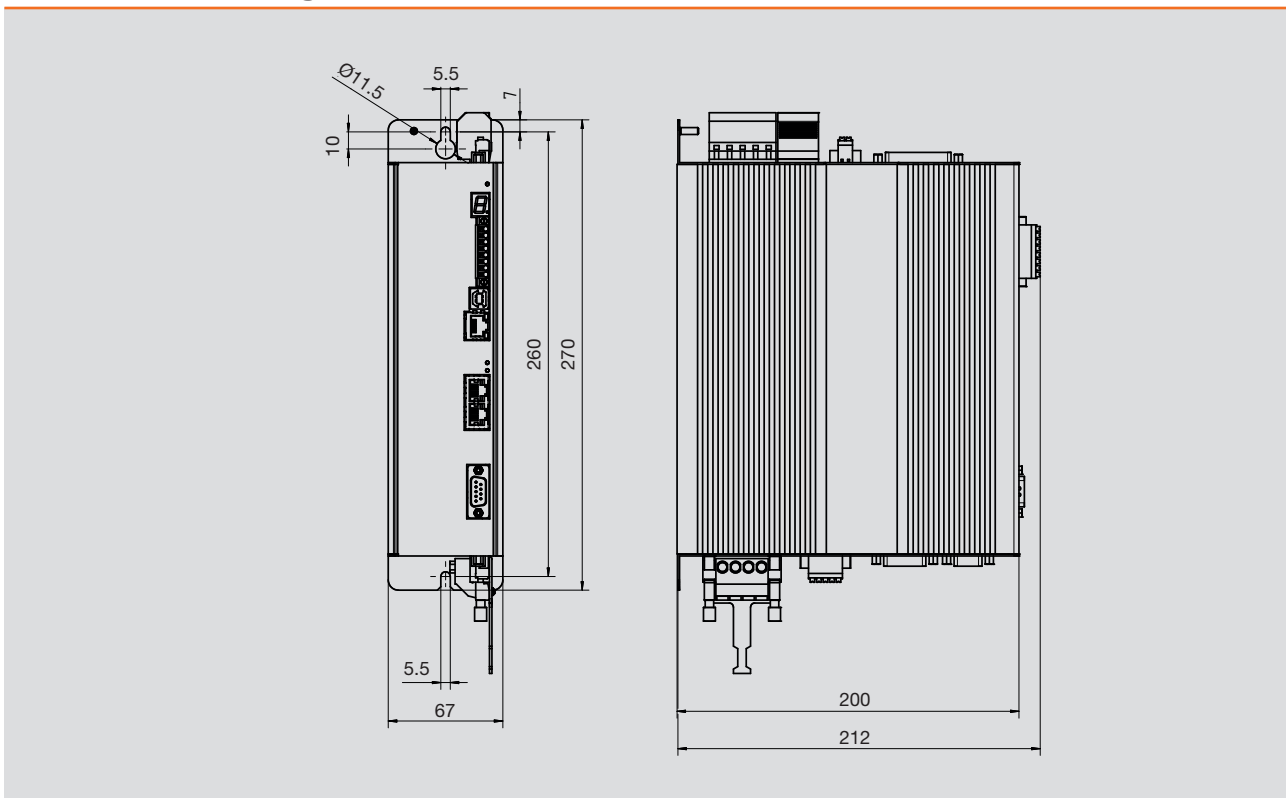

■ HCB Servo Drive

Three-phase

■ Specifications

	HCB 4/12-3	HCB 8/24-3	HCB 12/30-3	HCB 20/50-3	HCB 40/100-3
Voltage supply	3 x 230...480 V _{AC} [± 10 %], 45...66 Hz				
Control voltage	24 V _{DC} [± 20 %] (0.35 A)	24 V _{DC} [± 20 %] (0.45 A)	24 V _{DC} [± 20 %] (0.65 A)	24 V _{DC} [± 20 %] (max. 1 A)	
DC link voltage	565 V _{DC} (with U _{mains} = 400 V _{AC})				
Output power	1.6 kW	3.2 kW	4.8 kW	8 kW	16 kW
Max. output power for 2 s	4.8 kW	9.6 kW	12 kW	20 kW	40 kW
Rated output current	4 A _{rms}	8 A _{rms}	12 A _{rms}	20 A _{rms}	40 A _{rms}
Max. output current for 2s	12 A _{rms}	24 A _{rms}	30 A _{rms}	50 A _{rms}	100 A _{rms}
Internal brake resistor	30 Ω				15 Ω
Continuous power / pulse power	50 W to 24 kW			80 W	160 W
External brake resistor	≥ 30 Ω			15 Ω ≤ R _{ex} ≤ 50 Ω	15 Ω ≤ R _{ex} ≤ 50 Ω
Holding brake	24 VDC, max. 2A				
Dimensions servo drive H x W x D	230 x 67 x 200 mm 275 x 67 x 200 mm with mounting plate			351 x 90.5 x 256.5 mm 390 x 93 x 263 mm with mounting plate	351 x 162.5 x 256.5 mm 390 x 165 x 263 mm with mounting plate
Weight	2,9 kg		8,0 kg		13,5 kg
Encoder evaluation	EnDat 2.2, HIPERFACE®, HIPERFACE DSL®, resolver, analog and digital incremental encoders with/without commutation signals, BiSS (Type C)				
Interfaces	USB 2.0, Ethernet, CAN, EtherCAT®, PROFINET®, MicroSD card			USB 2.0, Ethernet, CAN, EtherCAT®, PROFINET®, MicroSD card, Ethernet Powerlink*	USB 2.0, Ethernet, CAN, EtherCAT®, PROFINET®, MicroSD card, Ethernet Powerlink*
Inputs / outputs	8 x digital in (24 V _{DC}), 2 x analog in (± 10 V) 3 x digital out (24 V _{DC})				
Product numbers	12-405-020-11-0	12-405-020-12-0	12-405-020-13-0	12-405-020-14-0	12-405-020-15-0

* On request

Dimensional Drawing HCB 4/12-3, HCB 8/24-3, HCB 12/30-3

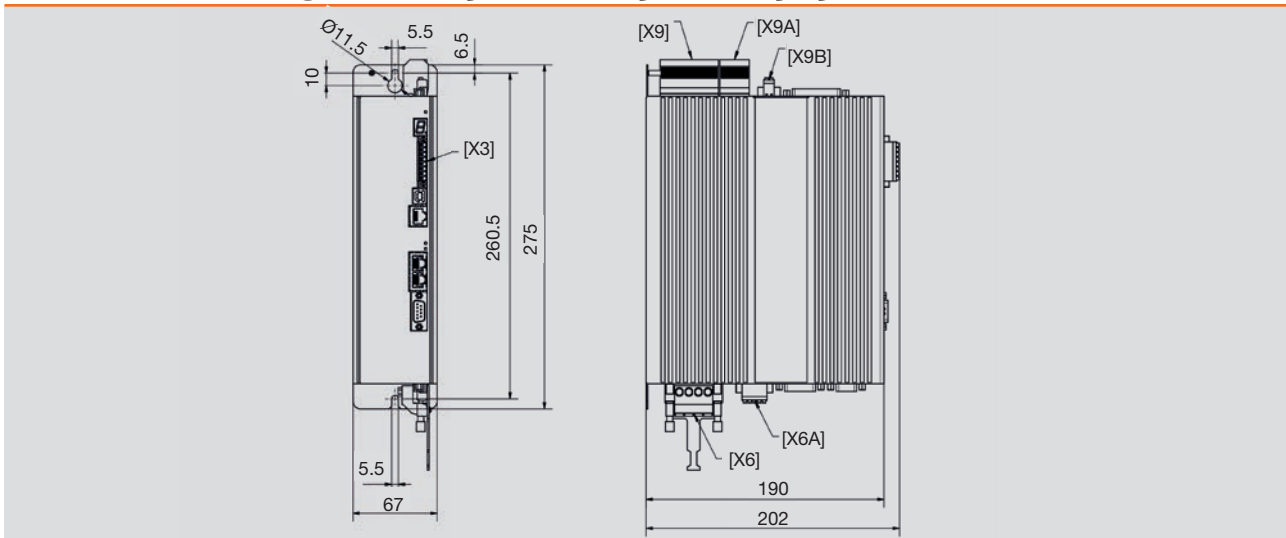

Dimensional Drawing HCB 20/50-3

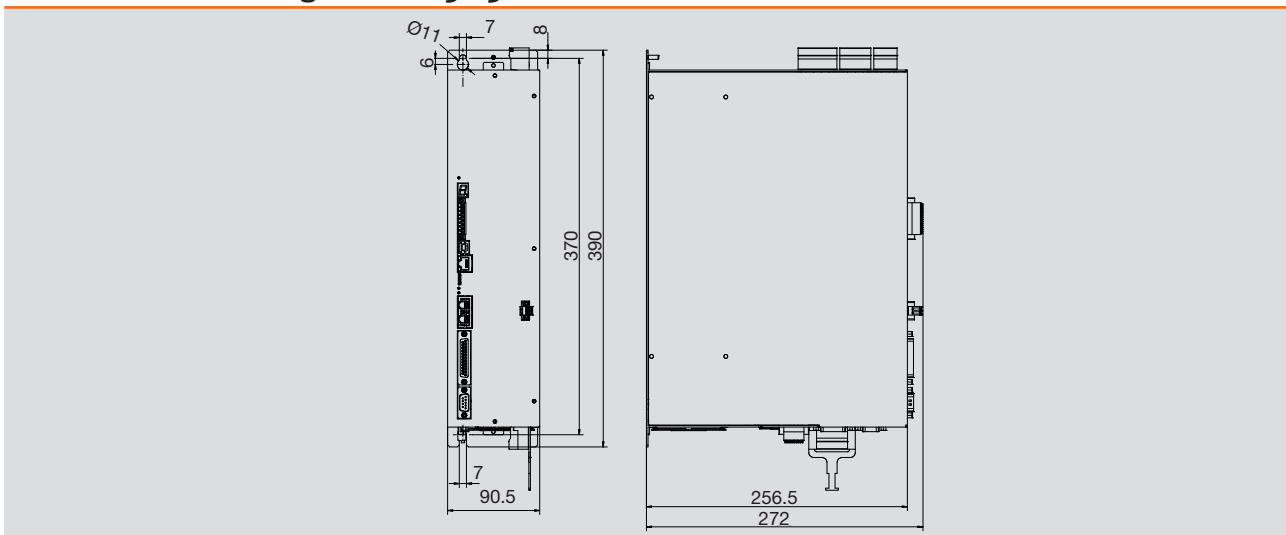

Dimensional Drawing HCB 40/100-3

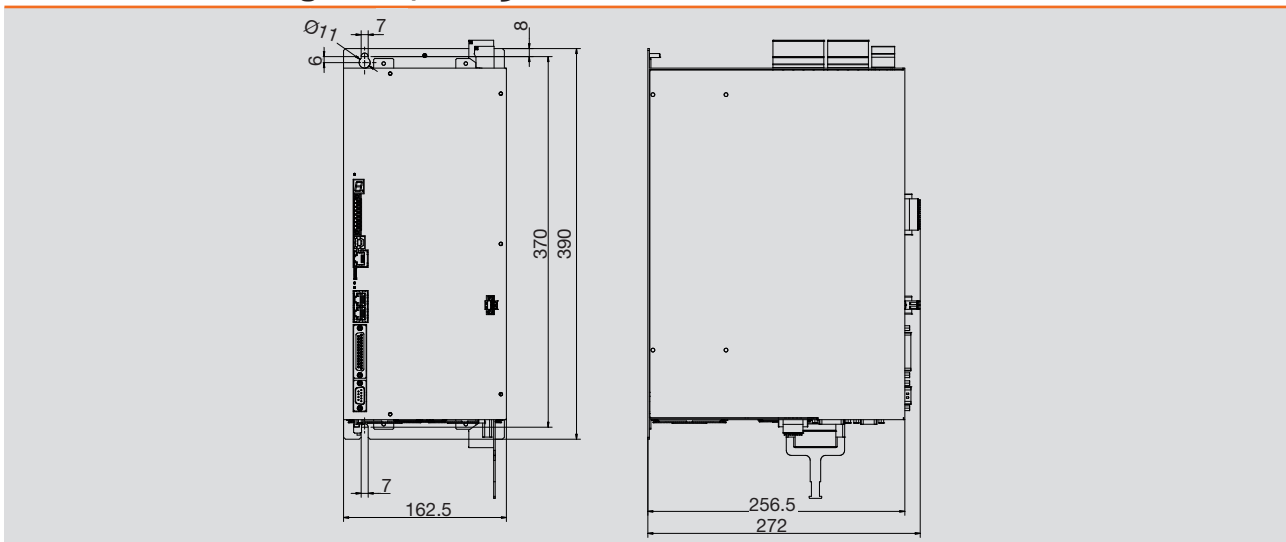

■ HCB Servo Drive

Connectors Single-phase

Connector STO [X3]

14-001-015-22-0

Order code connectors single-phase



Pin	Name	Description
1	STOA	Control input A for the STO function
2	GND A	Reference potential for STO-A
3	STOB	Control input B for the STO function
4	GND B	Reference potential for STO-B
5	DIN6	Connected to X1, pin 22
6	DIN7	Connected to X1, pin 10
7	DOU0	Connected to X1, pin 12
8	GND	Reference potential for the auxiliary supply voltage

Pin Assignment [X6] - Motor with a Motor Temperature Sensor

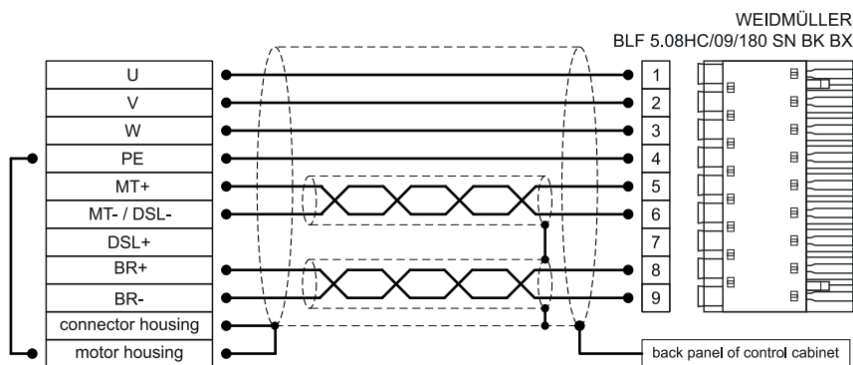

Pin	Name	Specification
1	U	Motor phase U
2	V	Motor phase V
3	W	Motor phase W
4	PE	Protective earth conductor of the motor
5	MT+	Motor temperature sensor +
6	MT-/DSL-	Motor temperature sensor -
7	DSL+	
8	BR+	Holding brake +
9	BR-	Holding brake -

Pin Assignment [X6] - Motor with HIPERFACE DSL

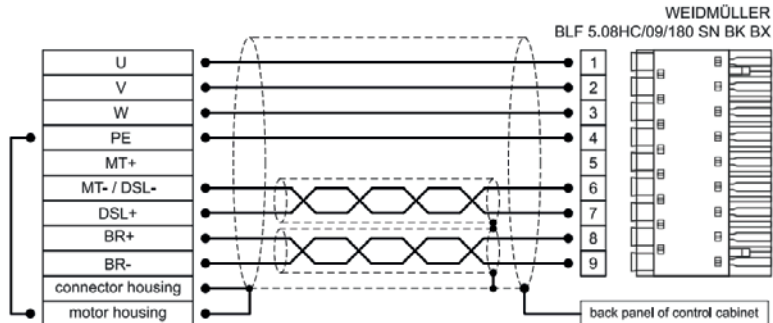

Pin	Name	Specification
1	U	Motor phase U
2	V	Motor phase V
3	W	Motor phase W
4	PE	Protective earth conductor of the motor
5	MT+	
6	MT-/DSL-	HIPERFACE DSL® -
7	DSL+	HIPERFACE DSL® +
8	BR+	Holding brake +
9	BR-	Holding brake -

Pin Assignment Power Supply [X9]

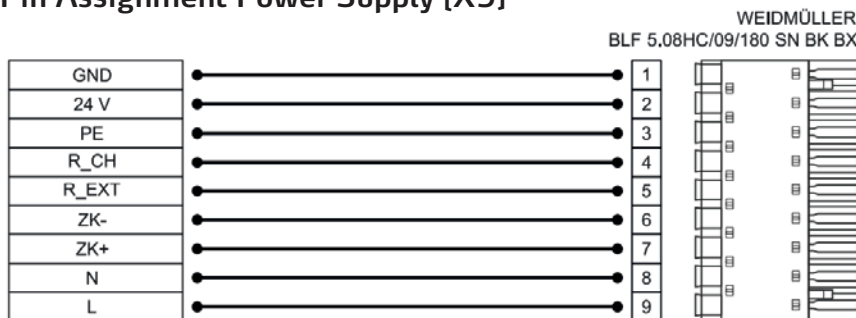

Pin	Name	Specification
1	GND	Supply voltage reference potential
2	24 V	Supply voltage for the control module and holding brake
3	PE	Connection of the protective earth (ground) conductor of the mains power supply
4	R_CH	Braking resistor connection
5	R_EXT	Braking resistor connection
6	ZK-	Neg. DC bus voltage
7	ZK+	Pos. DC bus voltage
8	N	Neutral conductor
9	L	Phase conductor/mains phase

■ HCB Servo Drive

Connectors three-phase

14-001-015-35-0

Order code connectors three-phase

Pin Assignment [X6, X6A] - Motor with HIPERFACE DSL

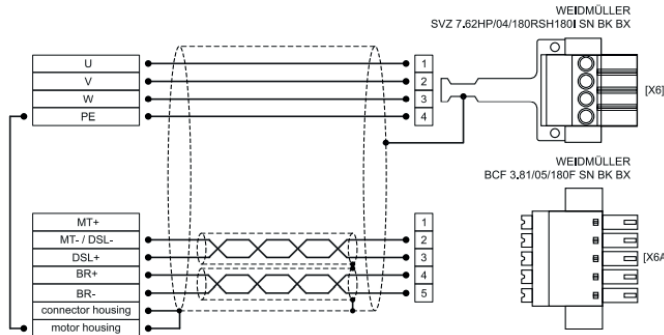

Pin X6	Name	Specification
1	U	Motor phase U
2	V	Motor phase V
3	W	Motor phase W
4	PE	Protective earth conductor of the motor
Pin X6A	Name	Specification
1	MT+	
2	MT-/DSL-	HIPERFACE DSL® -
3	DSL+	HIPERFACE DSL® +
4	BR+	Holding brake +
5	BR-	Holding brake -

Pin Assignment [X6, X6A] - Motor with a Motor Temperature Sensor

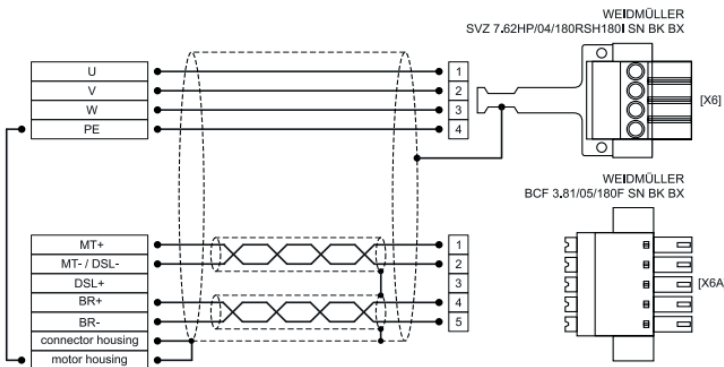

Pin X6	Name	Specification
1	U	Motor phase U
2	V	Motor phase V
3	W	Motor phase W
4	PE	Protective earth conductor of the motor
Pin X6A	Name	Specification
1	MT+	Motor temperature sensor +
2	MT-/DSL-	Motor temperature sensor -
3	DSL+	
4	BR+	Holding brake +
5	BR-	Holding brake +-

Connector STO [X3]



Pin	Name	Description
1	STOA	Control input A for the STO function
2	GNDA	Reference potential for STO-A
3	STOB	Control input B for the STO function
4	GNDB	Reference potential for STO-B
5	DIN6	Connected to [X1], pin 22
6	DIN7	Connected to [X1], pin 10
7	DOU0	Connected to [X1], pin 12
8	GND	Reference potential for the auxiliary supply voltage

Connector Power Supply [X9], [X9A], [X9B]

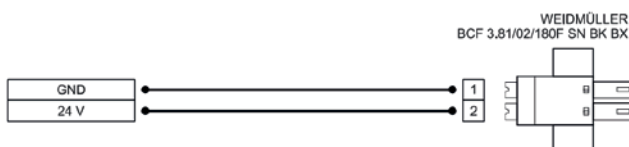
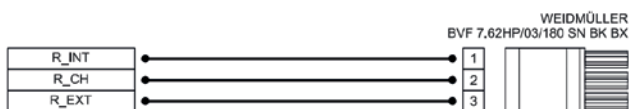
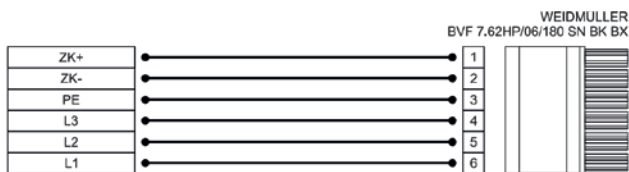

Pin X9	Name	Specification
1	ZK+	Pos. DC bus voltage
2	ZK-	Neg. DC bus voltage
3	PE	Connection of the protective earth (ground) conductor of the mains power supply
4	L3	Phase conductor / mains phase 3
5	L2	Phase conductor / mains phase 2
6	L1	Phase conductor / mains phase 1

Pin X9A	Name	Specification
1	R_INT	Internal braking resistor connection
2	R_CH	Braking resistor connection
3	R_EXT	External braking resistor connection

The connection for the braking resistor (X9A) is supplied with the servo controller (already fitted).

Pin X9B	Name	Specification
1	GND	Supply voltage reference potential
2	24 V	Supply voltage for the control module and holding brake

■ HCL Servo Drive

Introduction and Sizes

■ Introduction

In addition to the integrated controllers, the HCL servo controller series can be combined perfectly with our 24 V and 48 V motors of the HMD Next Generation series.

With a maximum current of up to 225 A peak, the controllers, in combination with our HMD servomotors, offer an ideal solution for demanding tasks.

This solution delivers an extremely cost-efficient package that includes a certified STO interface and UL recognition.

Thanks to their freely programmable Motion Process Unit (MPU), the controllers are ideal for simple control tasks. An additional PLC is often not required. EtherCAT® or CANopen® are two of the most common and proven fieldbuses available for use with an external PLC.

■ Functions

- "Safe Torque Off (STO)" safety function
- Device status display via three LEDs
- Freely programmable MPU (**M**otion **P**rocess **U**nit)
 - simple PLC functionality
- Compact 4-quadrant controller
- Vector controlled
- Galvanically isolated fieldbus interfaces

■ Accessories

HCL stick – USB/CAN program interface

The HCL stick connects the HCL CAN controller to your Windows® computer via its USB interface. This makes it easy to commission, parameterize and program the controller using the software tools that we provide for the controllers.

HCL brake – brake chopper for mains-powered systems

The HCL brake chopper effectively cuts overvoltages and redirects braking energy to an external load resistor. To protect all components in the DC link, the overvoltage threshold can be set using a DIP switch. The maximum peak braking current is 55 A when an external 1 Ohm load resistor is connected (not included in the scope of delivery).

■ Sizes



	HCL 60 C		HCL 120 C / E		HCL 225 CS		HCL 225 C / E		
Electronic supply voltage U_e	18-30 V		18-30 V		9-30 V		9-30 V		
Power supply voltage U_p	9-60 V		9-60 V		9-60 V		9-60 V		
Max. output current	42.5 A _{rms}		85 A _{rms}		159 A _{rms}		159 A _{rms}		
Continuous output current (UL/CE) ≤ 24 V	14.5 A _{rms}		-		54.5 A _{rms}		54.5 A _{rms}		
Continuous output current (UL/CE) ≤ 60 V	9.5 A _{rms}		18.5 A _{rms}		46 A _{rms}		46 A _{rms}		
STO	Yes		Yes		Yes		Yes		
Encoder supply	5 V / 0.2 A		5 V / 0.2 A		5 V / 0.2 A		5 V / 0.2 A		
Motor feedback types	HES1-002 / 12 bit singletum (SSI) HES3 / 2048 ppr / 8192 cpr (incremental encoder) HS16 / 16 bit singletum (SSI) HM16 / 16 bit singletum / 12 bit multitum (incremental encoder)					HES3 / 2048 ppr / 8192 cpr (incremental encoder)			
Fieldbus	CAN		CAN	EtherCAT®	CAN		CAN	EtherCAT®	
Galvanically isolated	No		No		Yes		Yes		
Size	78 x 74 x 29 mm		87 x 74 x 29 mm	87 x 74 x 49 mm	111 x 100 x 56 mm		111 x 100 x 39 mm	78 x 74 x 29 mm	
Weight	95 g		155 g		226 g		451 g	630 g	
Number of inputs/outputs	6 digital IN / 3 digital OUT / 1 analog IN					6 digital IN / 3 digital OUT / 2 analog IN			
Product numbers	12-001-014-22		12-001-014-20	12-001-014-21	12-001-014-19		12-001-014-17	12-001-014-18	

HCL Servo Drive

Hardware Equipment

Hardware Equipment

Performance Data

Mains voltage	1 x 30 V _{DC}
Rated current at 24 V _{AC}	14.5 - 54.5 A _{rms}
Rated current at 60 V _{AC}	9.5 - 46 A _{rms}

Safety Technology

STO - Safe Torque Off	■
Integrated safety control	-

Control Hardware

Analog inputs (± 10 V DC, 12 bit)	■ 2
Digital inputs / outputs - standard	■ 6/3
Motor temperature monitoring	■ PT1000, KTY

Encoder Systems

SSI	□
BiSS	□
Incremental encoder	■

Field Bus Systems

CAN	□
EtherCAT®	□

Cooling Concept

Air cooling	■
-------------	---

Ambient Conditions

Protection class	IP20 except clamps (IP00)
Accident prevention regulation	In conformity with local regulations (in Germany e. g. DGUV regulation 3)
Mounting method	Installation only for vertical mounting into a switch cabinet with protection class at least IP4x, if using the safety function STO at least IP54

Climate Conditions

During transportation	According to EN 61800-2, IEC 60721-3-2 class 2K3 ¹⁾
	Temperature: - 40 °C to + 80 °C
	Relative humidity: 5 % - 90%
During storage	According to EN 61800-2, IEC 60721-3-1 class 1K3 and 1K4 ²⁾
	Temperature: - 40 °C to + 80 °C
	Relative humidity: 5 to 95 %
During operation	According to EN 61800-2, IEC 60721-3-3 class 3K3 ³⁾
	Temperature: - 40 °C to + 40 °C (4 kHz), up to 55 °C with power reduction (2% / °C) - 40 °C to + 40 °C (8,16 kHz), up to 55 °C with power reduction (2 % / °C)
	Relative humidity: 5 to 90 % without condensation

1) Absolute humidity is limited to maximum 60 g/m³. That means that e.g. at 70 °C the relative humidity may only account for maximum 40 %.

2) Absolute humidity is limited to maximum 29 g/m³. The maximum values for temperature and relative humidity listed in the table must not occur simultaneously with the maximum humidity.

3) Absolute humidity is limited to maximum 25 g/m³. That means that the maximal values for temperature and relative humidity listed in the table must not occur simultaneously.

■ HCL Servo Drive

60 C

Specifications

	HCL 60 C
Electronic supply voltage U_e	18 - 30 V
Power supply voltage U_p	9 - 60 V
Maximal output current	42.5 A _{rms}
Continuous output current (UL/CE) ≤ 24 V	14.5 A _{rms}
Continuous output current (UL/CE) ≤ 60 V	9.5 A _{rms}
PWM frequency	32 KHz
PWM mode	SVPWM
Motor types	Brushless motors, linear motors
STO	Yes
Security integrity level (SIL)	SIL 3
Performance level (PL)	PL e
Fieldbus	CAN
Galvanically isolated	No
CAN protocol	DS301
Encoder supply	5 V / 0.2 A
Encoder evaluation	SSI / incremental encoder / BiSS
Number of inputs / outputs	6 digital IN / 3 digital OUT / 1 analog IN
Size	78 x 74 x 29 mm
Assembly	Wall mounted
Installation requirements	IP54
Maximum operating ambient temperature	-40 °C to 55 °C

Dimensional Drawing

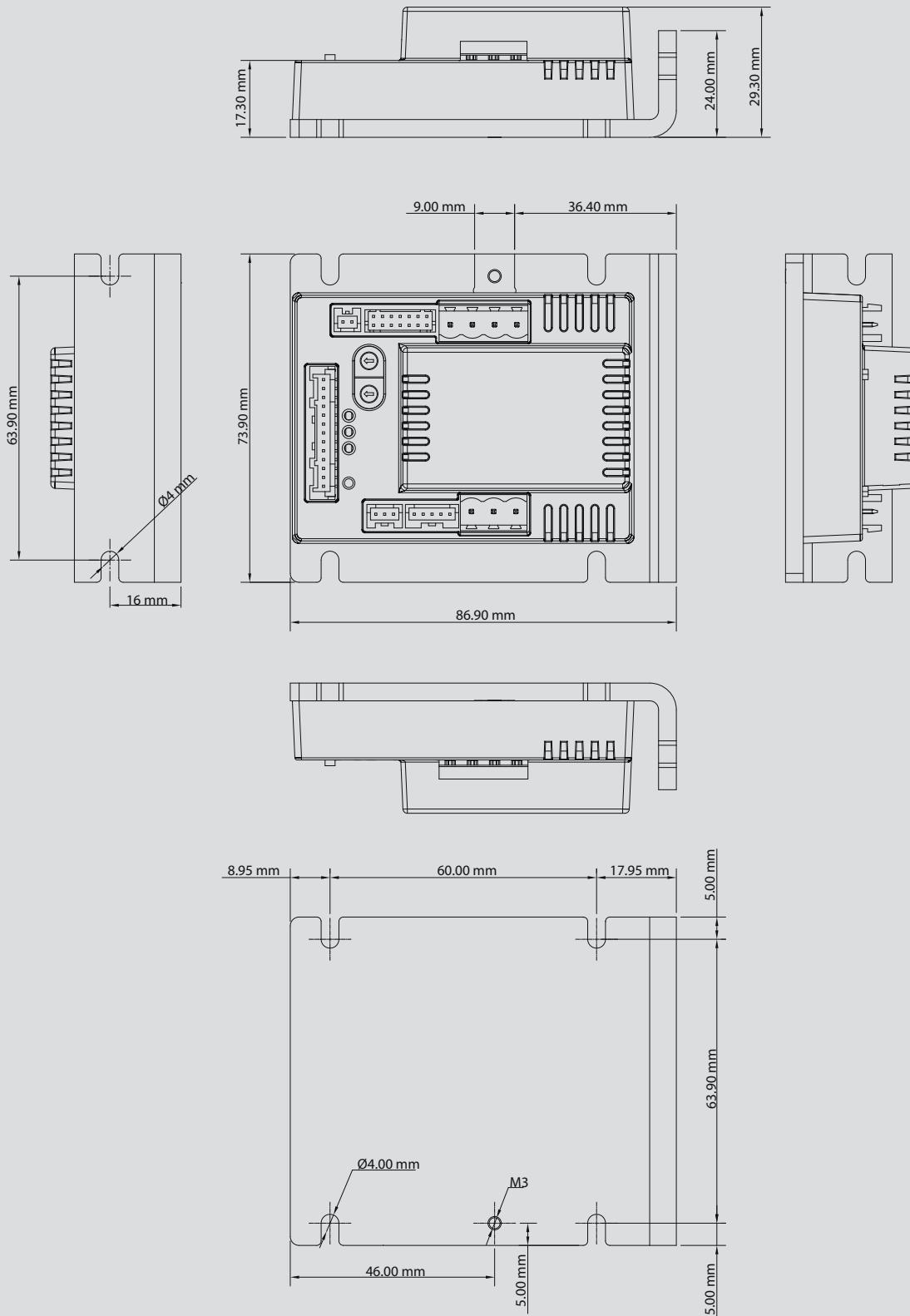

■ HCL Servo Drive

120 C / E

Specifications	HCL 120 C	HCL 120 E
Electronic supply voltage U_e	18 - 30 V	
Power supply voltage U_p	9 - 60 V	
Maximal output current	85 A _{rms}	
Continuous output current (UL/CE) ≤ 24 V	-	
Continuous output current (UL/CE) ≤ 60 V	18.5 A _{rms}	
PWM frequency	32 KHz	
PWM mode	SVPWM	
Motor types	Brushless motors, linear motors	
STO	Yes	
Security integrity level (SIL)	SIL 3	
Performance level (PL)	PL e	
Fieldbus	CAN	EtherCAT®
Galvanically isolated	No	Yes
CAN protocol	DS301	
Encoder supply	5 V / 0.2 A	
Encoder evaluation	SSI / incremental encoder / BiSS	
Number of inputs / outputs	6 digital IN / 3 digital OUT / 1 analog IN	
Size	87 x 74 x 29 mm	87 x 74 x 49 mm
Assembly	Wall mounted	
Installation requirements	IP54	
Maximum operating ambient temperature	-40 °C to 55 °C	

Dimensional Drawing HCL 120 C

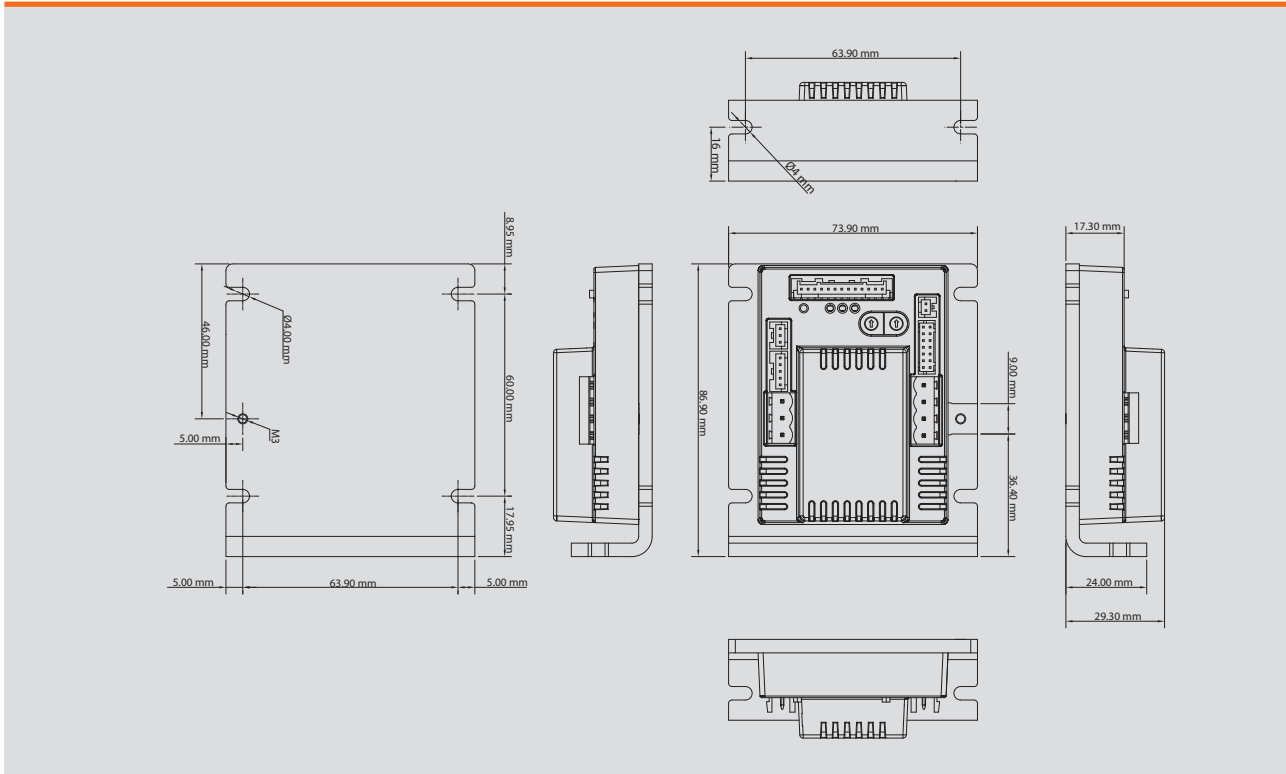

Dimensional Drawing HCL 120 E

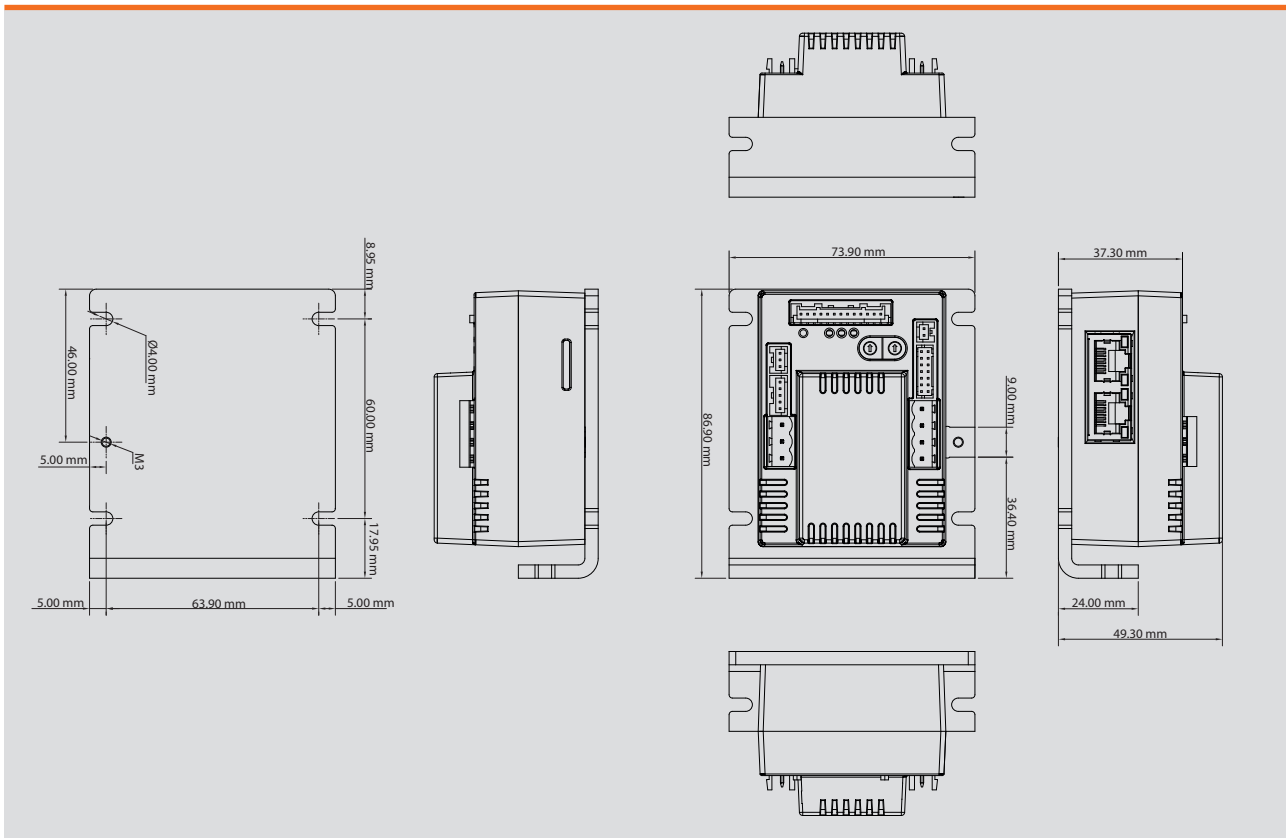

■ HCL Servo Drive

225 CS

Specifications

	HCL 225 CS
Electronic supply voltage U_e	9 - 30 V
Power supply voltage U_p	9 - 60 V
Maximal output current	159 A _{rms}
Continuous output current (UL/CE) ≤ 24 V	54.5 A _{rms}
Continuous output current (UL/CE) ≤ 60 V	46 A _{rms}
PWM frequency	32 KHz
PWM mode	SVPWM
Motor types	Brushless motors, linear motors
STO	Yes
Security integrity level (SIL)	SIL 3
Performance level (PL)	PL e
Fieldbus	CAN
Galvanically isolated	Yes
CAN protocol	DS301
Encoder supply	5 V / 0.2 A
Encoder evaluation	SSI / incremental encoder / BiSS
Number of inputs / outputs	6 digital IN / 3 digital OUT / 2 analog IN
Size	111 x 100 x 56 mm
Assembly	Wall
Installation requirements	IP54
Maximum operating ambient temperature	-40 °C to 40 °C

Dimensional Drawing

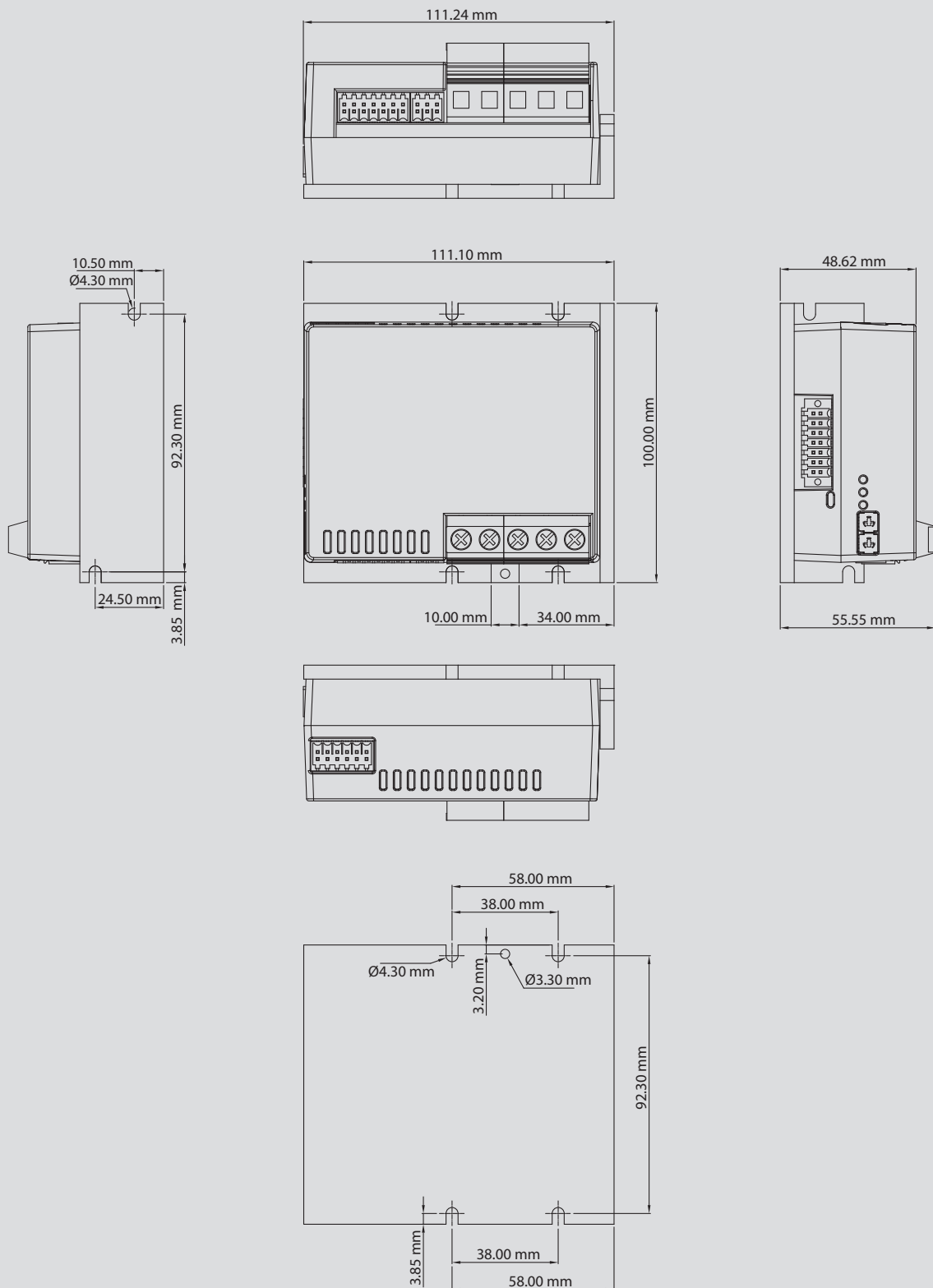

■ HCL Servo Drive

225 C / E

Specifications	HCL 225 C	HCL 225 E
Electronic supply voltage U_e	9 - 30 V	
Power supply voltage U_p	9 - 60 V	
Maximal output current	159 A _{rms}	
Continuous output current (UL/CE) ≤ 24 V	54.5 A _{rms}	
Continuous output current (UL/CE) ≤ 60 V	46 A _{rms}	
PWM frequency	32 KHz	
PWM mode	SVPWM	
Motor types	Brushless motors, linear motors	
STO	Yes	
Security integrity level (SIL)	SIL 3	
Performance level (PL)	PL e	
Fieldbus	CAN	EtherCAT®
Galvanically isolated	Yes	
CAN protocol	DS301	
Encoder supply	5 V / 0.2 A	
Encoder evaluation	SSI incremental encoder / BiSS	
Number of inputs / outputs	6 digital IN / 3 digital OUT / 2 analog IN	
Size	111 x 100 x 39 mm	78 x 74 x 29 mm
Assembly	Wall mounted	
Installation requirements	IP54	
Maximum operating ambient temperature	-40 °C to 40 °C	

Dimensional Drawing HCL 225 C

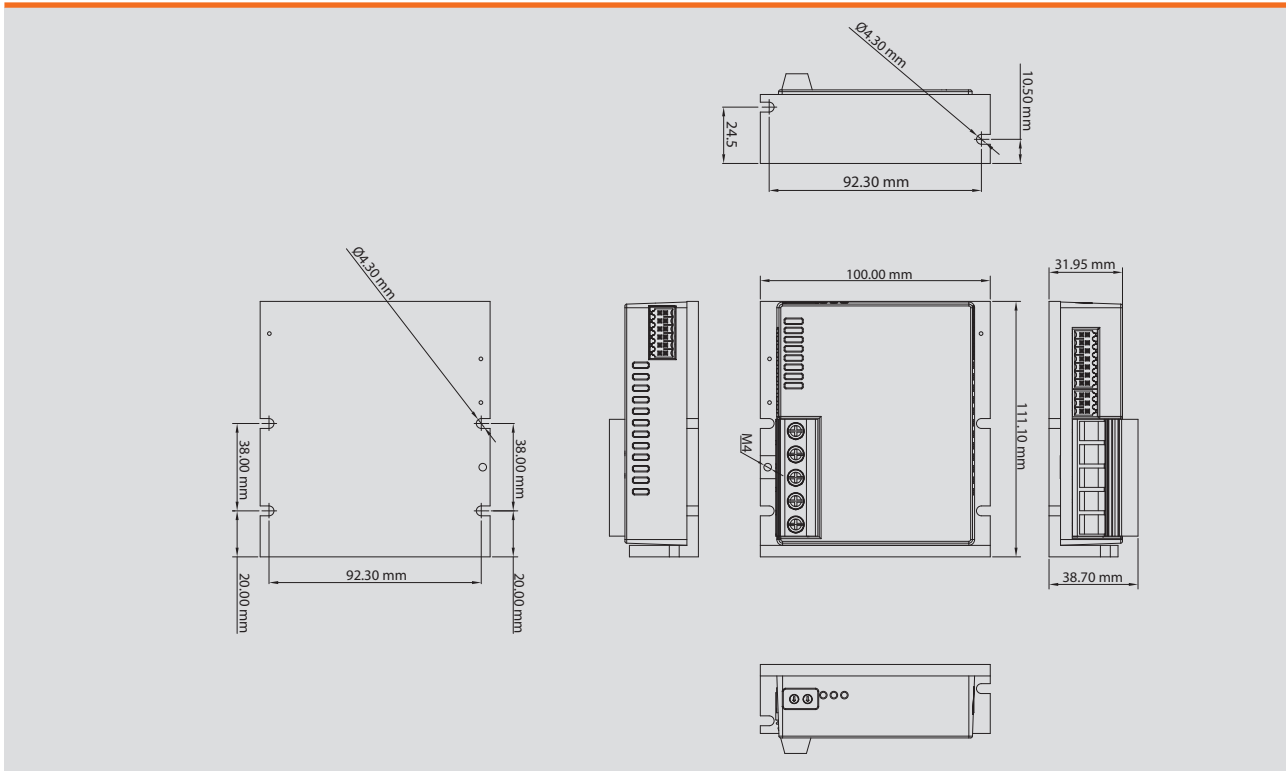

Dimensional Drawing HCL 225 E

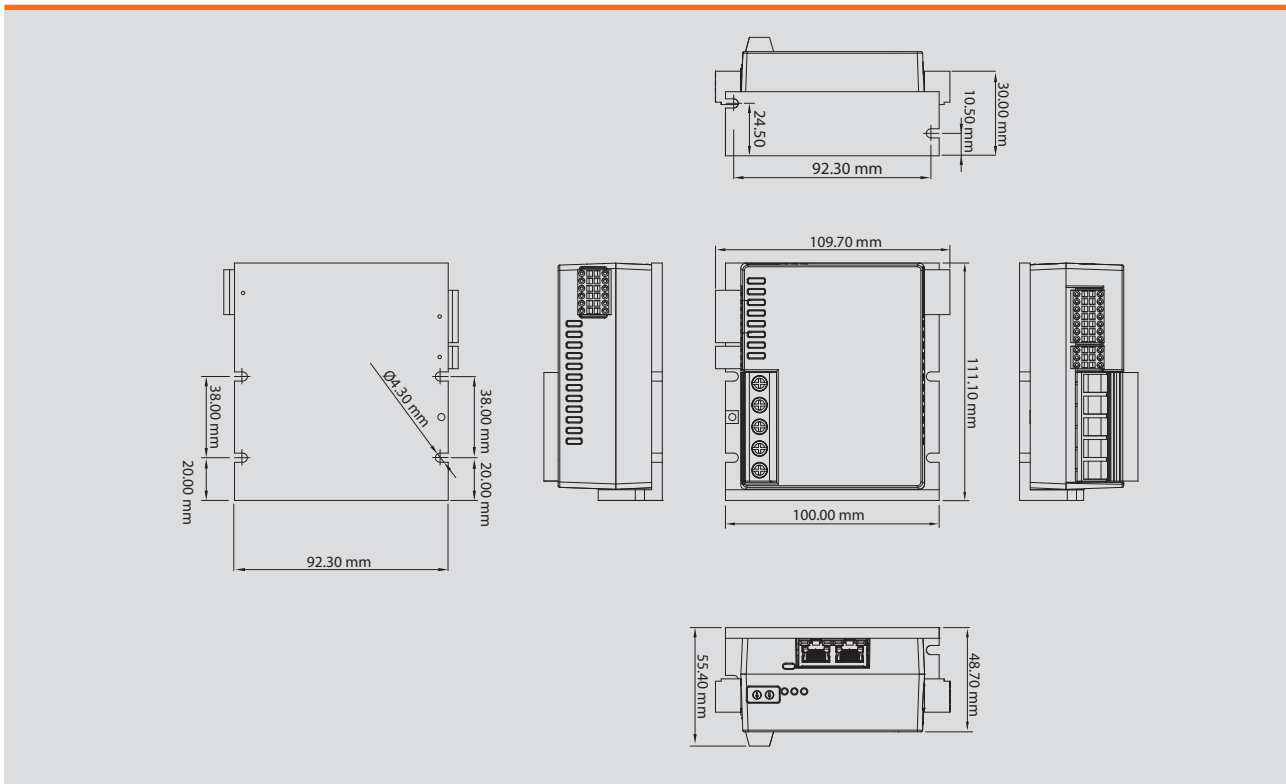

HCL Servo Drive

Connectors

HCL 60 C and HCL 120 C / E



Terminal	Signal	Description
X1.1	GND	Ground electronics
X1.2	+Ue24V	Supply voltage electronics
X1.3	GND	Ground power
X1.4	+Up	Supply voltage power

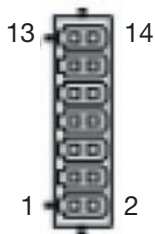

Terminal	Signal	Description
X2.1	CLK	SSI clk
X2.2	/CLK	/SSI clk
X2.3	DATA	SSI data
X2.4	/DATA	/SSI data
X2.5	res.	Reserved
X2.6	GND	Ground for encoder supply. Do not connect to system ground.
X2.7	A	Incremental encoder - track A
X2.8	/A	Incremental encoder - track A negated
X2.9	B	Incremental encoder - track B
X2.10	/B	Incremental encoder - track B negated
X2.11	Inx	Incremental encoder - index
X2.12	/Inx	Incremental encoder - index negated
X2.13	+5V	5V output voltage for encoder supply. Sensors: endoder, SSI
X2.14	GND	Ground for encoder supply. Do not connect to system ground.



Terminal	Signal	Description
X3.1	PT_A	PT_A
X3.2	PT_B	PT_B



Terminal	Signal	Description
X4.1	STO-B	STO channel B
X4.2	Din0	Digital input 0
X4.3	Din1	Digital input 1
X4.4	Din2	Digital input 2
X4.5	Din3	Digital input 3
X4.6	Din4	Digital input 4
X4.7	Din5	Digital input 5
X4.8	STO-A	STO channel A
X4.9	Ain0	Analog input 0
X4.10	Ain1	Analog input 1
X4.11	Dout0	Analog input 0
X4.12	Dout1	Analog input 1
X4.13	Dout2	Analog input 2

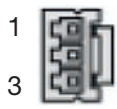

Terminal	Signal	Description
X5.1	CAN Hi	CAN High
X5.2	CAN Lo	CAN Low
X5.3	CAN GND	Ground for CAN

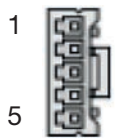

Terminal	Signal	Description
X6.1	H1	Hall sensor signal 1
X6.2	H2	Hall sensor signal 2
X6.3	H3	Hall sensor signal 3
X6.4	+U5V	5V output voltage for encoder supply. Sensors: hall
X6.5	GND	Ground for encoder supply. Do not connect to system ground.



Terminal	Signal	Description
X7.1	Ma	Motor phase A
X7.2	Mb	Motor phase B
X7.3	Mc	Motor phase C



Terminal	Signal	Description
S1	FE	Functional ground

HCL Servo Drive

Connectors

HCL 225 CS / C / E



Terminal	Signal	Description
X1.1	+UP	Supply voltage power
X1.2	GND	Ground power
X1.3	Ma	Motor phase A
X1.4	Mb	Motor phase B
X1.5	Mc	Motor phase C

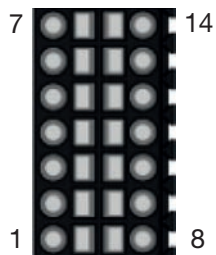

Terminal	Signal	Description
X2.1	H1	Hall sensor signal 1
X2.2	H2	Hall sensor signal 2
X2.3	H3	Hall sensor signal 3
X2.4	A	Incremental encoder - channel A
X2.5	B	Incremental encoder - channel B
X2.6	Inx	Incremental encoder - Index
X2.7	+U5V	5V output voltage for encoder supply. Sensors: Rotary encoder, hall
X2.8	/H1	Hall sensor signal 1 negated
X2.9	/H2	Hall sensor signal 2 negated
X2.10	/H3	Hall sensor signal 3 negated
X2.11	/A	Incremental encoder - channel A negated
X2.12	/B	Incremental encoder - channel B negated
X2.13	/Inx	Incremental encoder - Index negated
X2.14	GND	Ground for encoder supply. Do not connect to system ground.

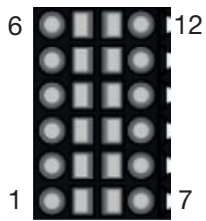

Terminal	Signal	Description
X3.1	+Ue24V	Supply voltage electronics
X3.2	+Ain0	Analog input 0, plus
X3.3	Din0	Digital input 0
X3.4	Din1	Digital input 1
X3.5	Din2	Digital input 2
X3.6	Din3	Digital input 3
X3.7	GND	Ground electronics
X3.8	-Ain0	Analog input 0, minus
X3.9	Dout0	Digital input 0
X3.10	CAN Hi	CAN High
X3.11	CAN Lo	CAN Low
X3.12	CAN GND	Ground for CAN

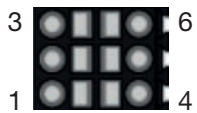

Terminal	Signal	Description
X4.1	Ain1	Analog input 1
X4.2	Din4	Digital input 4
X4.3	Din5/Dout2	Digital input 5 / digital output 2
X4.4	STO-A	STO channel A
X4.5	Dout1	Digital output 1
X4.6	STO-B	STO channel B



Terminal	Signal	Description
S1	FE	Functional ground

Technical data subject to change! Last changes 10/2024

Heidrive GmbH

Starenstraße 23
D-93309 Kelheim

Phone +49 9441/707-0
Fax +49 9441/707-259

info@heidrive.de
www.heidrive.com

